



Ficha tecnica Nº

**315**

FICHA TECNICA PARA CATEGORIA TURISMO INTERNACIONAL

**Valida a partir : 01 / 08 / 2023**

Auto visto de 3/4 delantero



Auto visto de 3/4 atras



Denominacion(s) comercial(e)s - **C 200**

Numeros de volumenes : 3

Numeros de plazas : 5

Longitud total : 4686 mm +/- 1 %

Diatancia entre ejes : 2760 mm +/- 1 %

Perfil motor : lado derecho desmontado



Perfil motor : lado izquierdo desmontado



Material del block cilindro :	Aluminio
Numeros y disposicion de cilindros :	6 en V
Cilindrada total original :	3498.0 cm <sup>3</sup>
Cilindrada unitaria. Original :	583 cm <sup>3</sup>
Diametro cilindro original :	92.9 +/- 0.1 mm
Cilindro Maximo autorizado :	+/- 0.1 mm
Cilindrada total :	3498.0 cm <sup>3</sup>
Carrera :	86 +/- 0.1 mm

Block motor visto : de arriba



Block motor : lado derecho

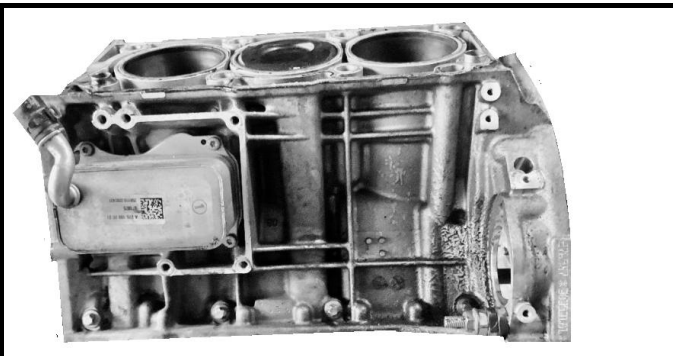

Block motor : lado volante

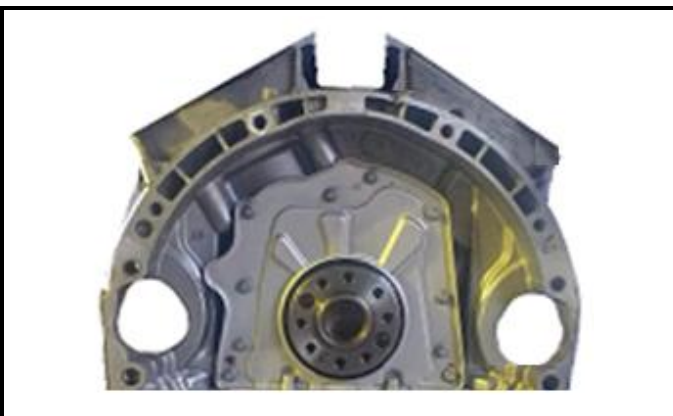

Block motor visto : de abajo

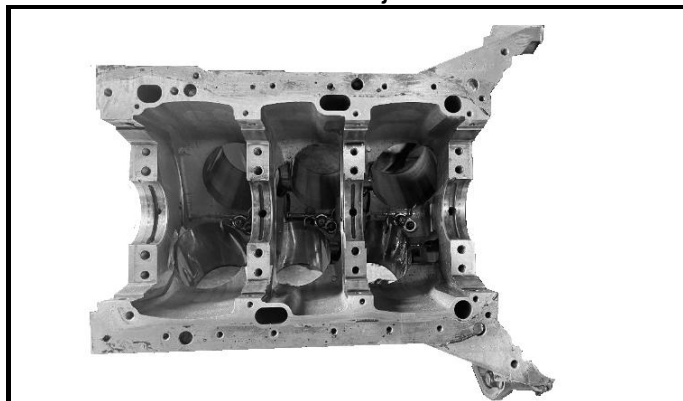

Block motor : lado izquierdo

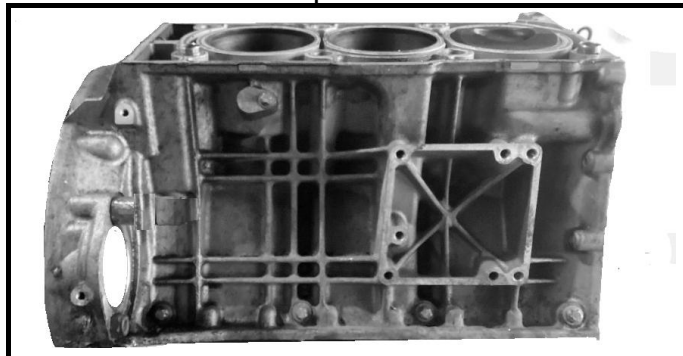

Block motor : lado distribucion



Tapa de bancada : visto de arriba

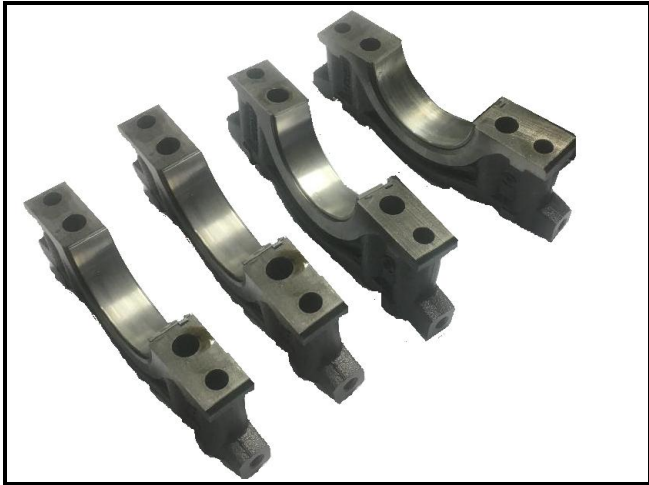

Tapa de bancada : visto de abajo



Biela original:

Acero

Acero

Tipo de biela :

Partida

2 partes

Diamètro intèrno de biela (sin cojinetes):

55,5 +/- 0.1 mm

Distancia entre ejes ;

150 +/- 0.1 mm

Peso minimo biela original,cojinetes, tornillos,piston ,perno y aros: 1022 g

Medida Aros piston: 1.2 1.5.2.0 mm

Diametro Perno piston: Diam 20 mm

Biela original :



Biela original:



Piston original: visto de costado



Piston original: visto de abajo



Cigüeñal tipo de construcción:

Forjado

Cigüeñal visto de frente

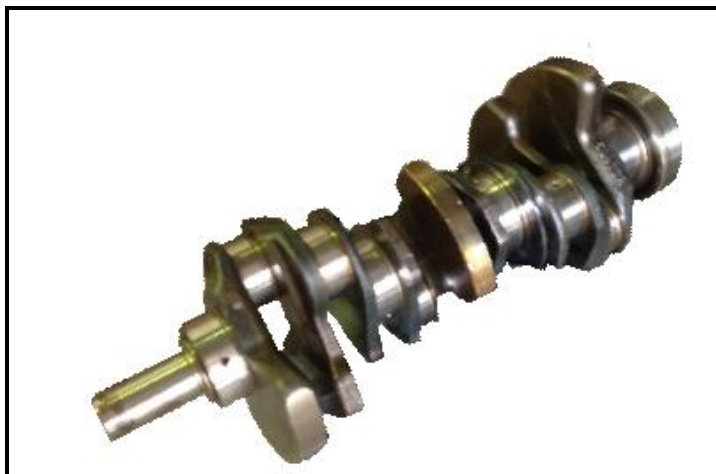

Cigüeñal visto de atrás

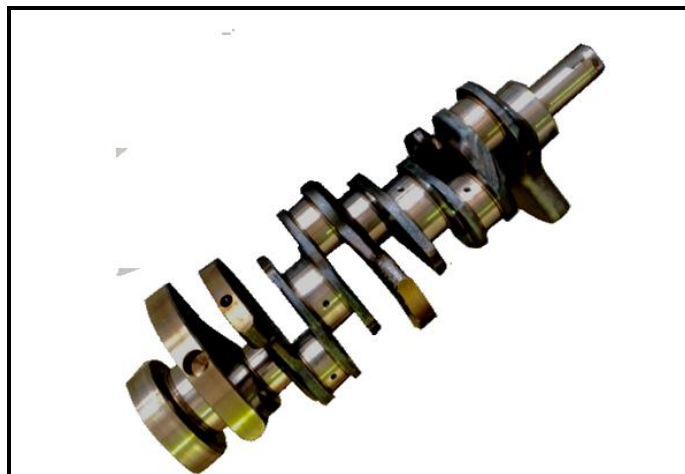

Peso minimo de cigüeñal :

g

Cantidad de apoyos :

4

Diametro muñon biela original :

52 +/- 0.1 mm

Diametro bancada original :

64 +/- 0.1 mm

Altura original block motor.

Centro cigüeñal y plano tapa cilindros :

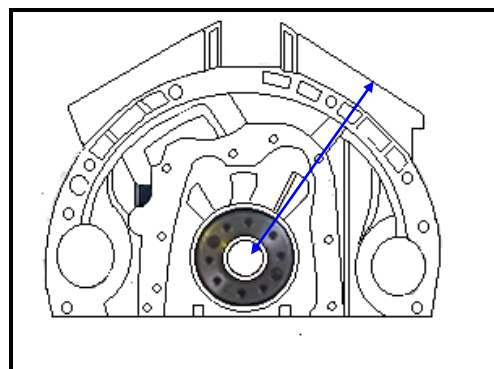

Volante motor :

Material :Acero

Tapa cilindros : Cantidad 2

Material : Aluminio

Tapa cilindros x 2 : visto de arriba

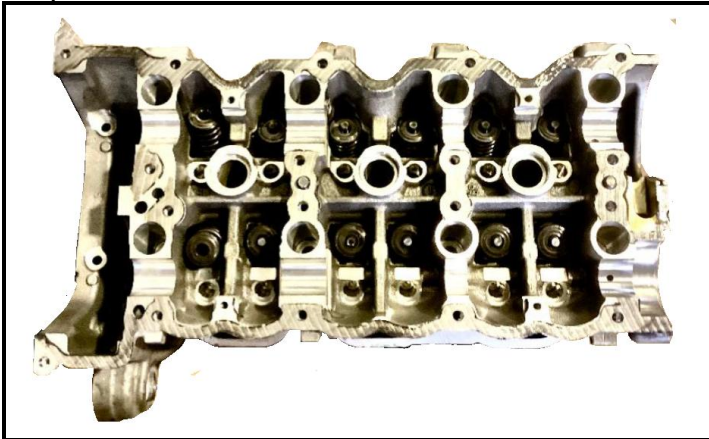

Tapa cilindros x 2 : visto de abajo.

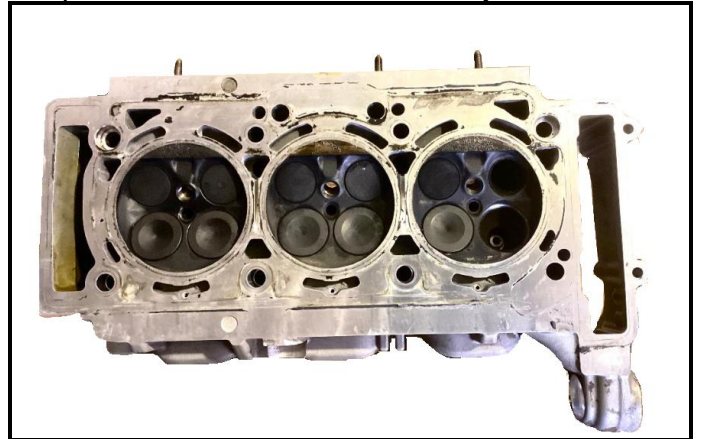

Tapa cilindros : visto lado admision



Tapa cilindros : visto ldo escape

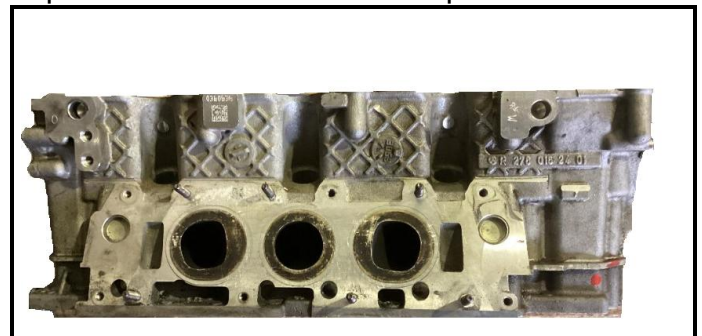

Tapa cilindros la izquierdo lado distribucion

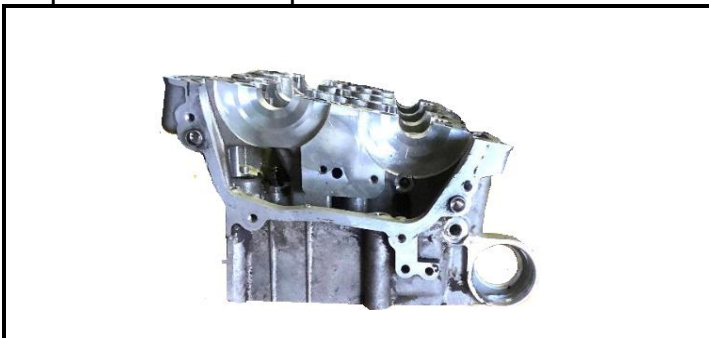

Tapa cilindros izquierdo : visto lado volante



Tapa cilindros derecho visto lado distribucion

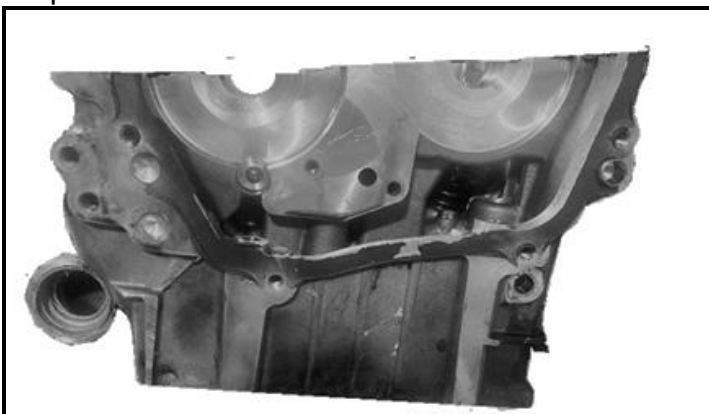

Tapa cilindros derecho: visto lado volante

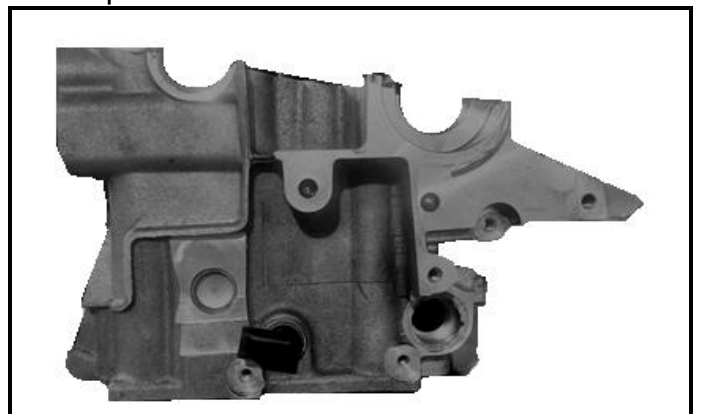

Camara combustión

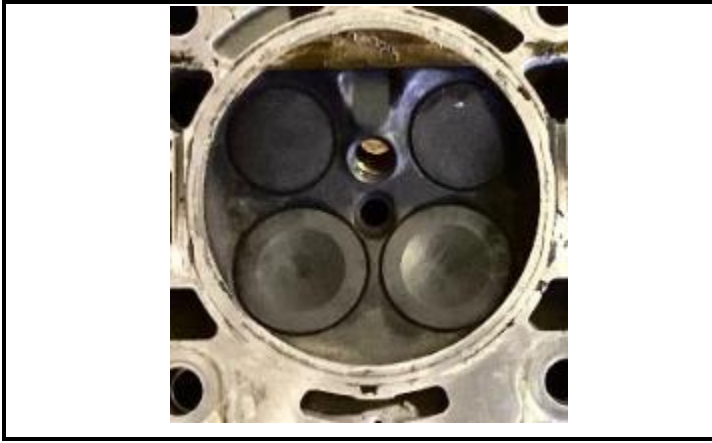

Camara combustión con bujía original



Bujía original N° ZR5S1332..279



Maxima relacion de compresion 12.0 a 1

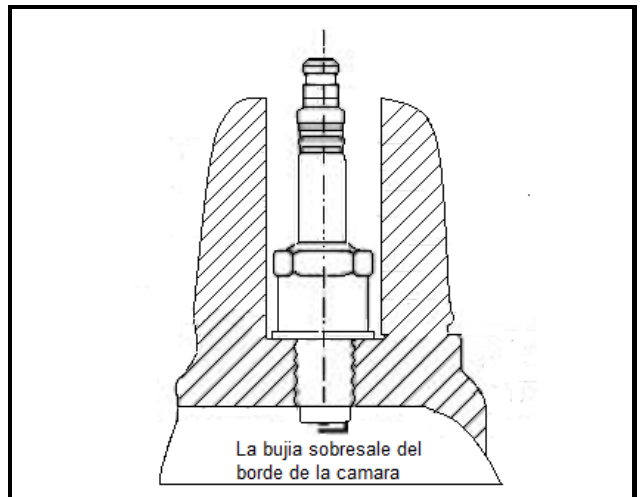

Alimentacion por inyeccion : Marca Modelo

Tipo de dosificacion de combustible :

<input type="checkbox"/> mecánica	<input checked="" type="checkbox"/> electrónica
-----------------------------------	-------------------------------------------------

Dimensiones cuerpo mariposa a nivel de estrangulacion. 74 +/- 0.25 mm

Cantidad de inyectores de combustible 6

Cuerpo mariposa : Original



Arboles de levas : Cantidad : 4

Localizacion : En tapa cilindros

Sistema de comando : Cadena

Numeros de soportes por arbol 4

Sistema de comando de valvulas :

Botador con balancin

Arbol levas : Diametro del cojinete. 26. mm x 4

Dimensiones de la leva.

Admision : A = 34 +/- 0.1 mm

B = 39.5 +/- 0.1 mm

Escape : A = 34 +/- 0.1 mm

B = 39 +/- 0.1 mm

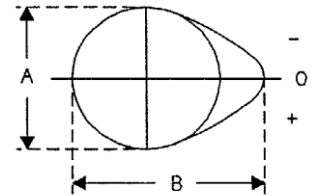

**Note : Las tolerancias deberan ser usadas con el mismo signo para A y B**

Distribucion : Juego de luz teorica de valvula : Admision 0 mm

Escape 0 mm

Alzada del arbol levas en mm (arbol desmontado)

Arbol levas admision : N° 2.090.276.33

Arbol levas escape : N° 2.070.276.03

ADMISION				ESCAPE			
Angle de rotation en degrés / Rotation angle in degrees	Levée en mm (+/- 0.1 mm) / Lift in mm (+/- 0.1 mm)	Angle de rotation en degrés / Rotation angle in degrees	Levée en mm (+/- 0.1 mm) / Lift in mm (+/- 0.1 mm)	Angle de rotation en degrés / Rotation angle in degrees	Levée en mm (+/- 0.1 mm) / Lift in mm (+/- 0.1 mm)	Angle de rotation en degrés / Rotation angle in degrees	Levée en mm (+/- 0.1 mm) / Lift in mm (+/- 0.1 mm)
0	<b>5.45</b>			0	<b>5.09</b>		
- 5	<b>5.40</b>	+ 5	<b>5.41</b>	- 5	<b>5.05</b>	+ 5	<b>5.05</b>
- 10	<b>5.25</b>	+ 10	<b>5.25</b>	- 10	<b>4.91</b>	+ 10	<b>4.91</b>
- 15	<b>4.99</b>	+ 15	<b>4.98</b>	- 15	<b>4.71</b>	+ 15	<b>4.69</b>
- 30	<b>3.59</b>	+ 30	<b>3.49</b>	- 30	<b>3.59</b>	+ 30	<b>3.46</b>
- 45	<b>1.56</b>	+ 45	<b>1.26</b>	- 45	<b>1.86</b>	+ 45	<b>1.41</b>
- 60	<b>0.14</b>	+ 60	<b>0.10</b>	- 60	<b>0.31</b>	+ 60	<b>0.11</b>
- 75	<b>0.00</b>	+ 75		- 75	<b>0.17</b>	+ 75	0.00

Un diferencia de + / - 2 grados se acepta de la medida total.

Alzada maxima en leva	
Admision	<b>+/- 0.2 mm</b>
Escape	<b>+/- 0.2 mm</b>

Botador : Admision / Escape



Dibujo : Botador y dimensiones

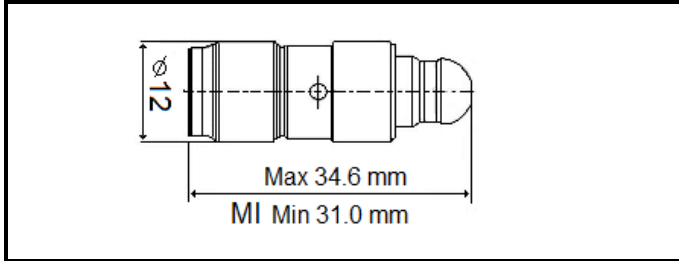

Admision : Material del multiple :  
Cantida de valvulas por cilindros :

Diametro maximo de valvulas admision :

Diametro de vastago de valvula en guia :

Largo de valvula :

Tipo de resortes de valvulas :

Cantidad resortes :

Escape : Material del multiple :

Cantida de valvulas por cilindro :

Diametro maximo de valvula escape :

Diametro de vastago de valvula en guia :

Largo de valvula :

Tipo de resorte de valvula :

Cantidad de resortes :

Multiple admision de plastico : frente



Balacin : Admision / Escape



Dibujo : Balacin y dimensiones

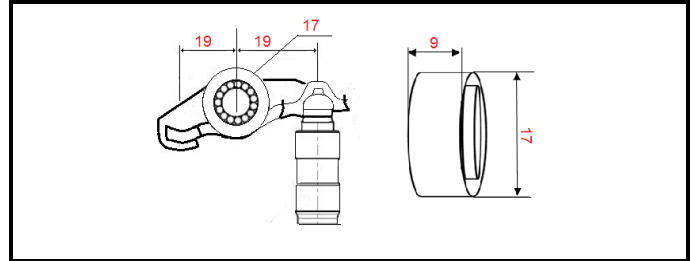

Plastico

2

37 mm

6 +/-0.2 mm

104. +/- 1.5 mm

Helicoidales

1

Acero .

2

30 mm

6 +/-0.2 mm

107.3 +/-1.5 mm

Helicoidal

1

Multiple de admision :atras





Orificio de Tapa Cilindros , lado multiple admision toléranca en las dimensiones +4 % - 2 % )

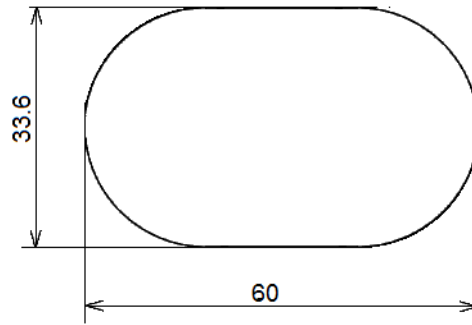

II) Orificio multiple admision lado tapa cilindro

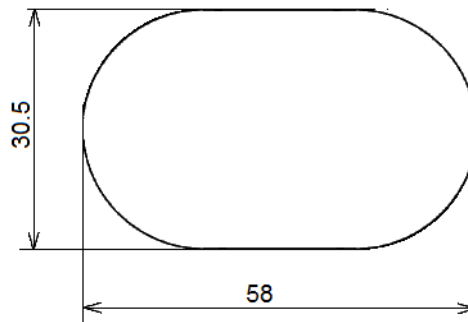

orificios de tapa cilindros lado escape : tolérancias en sus dimensiones +4% -2%

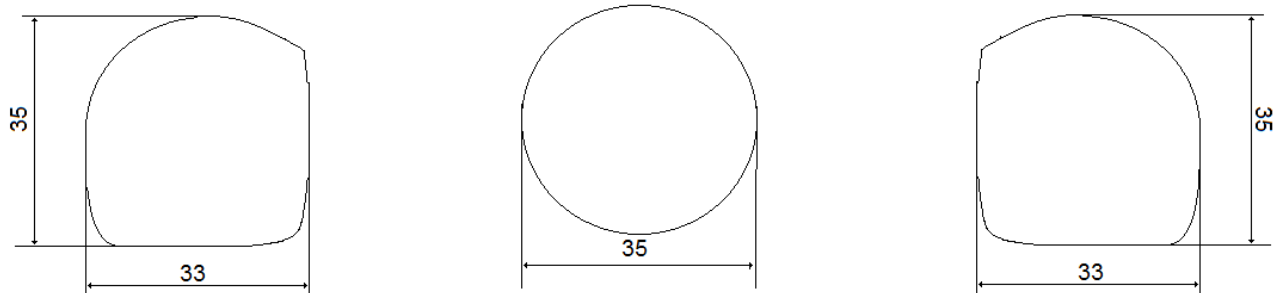

IV) Orificio colector de escape lado tapa cilindro

Sistema de ignicion :

Cantida de bujias por cilindros 1

Sistema de lubricacion : Carter Humedo

Numeros de distribuidores ///

cantidad de bombas de aceite 1

**CIRCUITO DE COMBUSTIBLE**

Tanque de combustible : 1

Emplazamiento Bajo piso parte trasera

**EQUIPO ELECTRICO**

Baterias : 1

Tension : 12 volts

**TRANSMISION :**

Ruedas motrices : Trasera

Embrague (Ver reglamento tecnico)

Caja de velocidades : Marca " ZF / Ge TRAG "

Emplazamiento del comando Piso del habitaculo

	N.Dientes	Radios	Sincr.
1	41 / 14	4.198	si
2	40 / 29	2.493	si
3	36 / 31	1.665	si
4	32 / 37	1.24	si
5	-----	1.0	si
M / A	23/28 :14/ 23	3.890	
Const	43.30	1.433	

	N Dientes	Radios	Sinc.
1	45 / 14	4.323	si
2	42 / 23	2.456	si
3	37/ 30	1.650	si
4	32/35	1.230	si
5	-----	1.000	si
6	29/46	0.848	si
M / A	23:14x41:23	3.938	
Const	39/29	1.345	

Grilla de velocidades

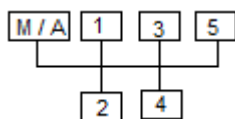

Carcasa de caja de velocidades de frente

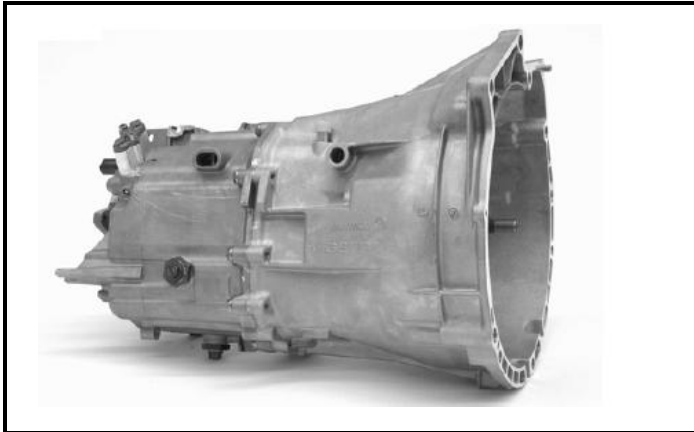

Caja velocidades : visto costado derecho

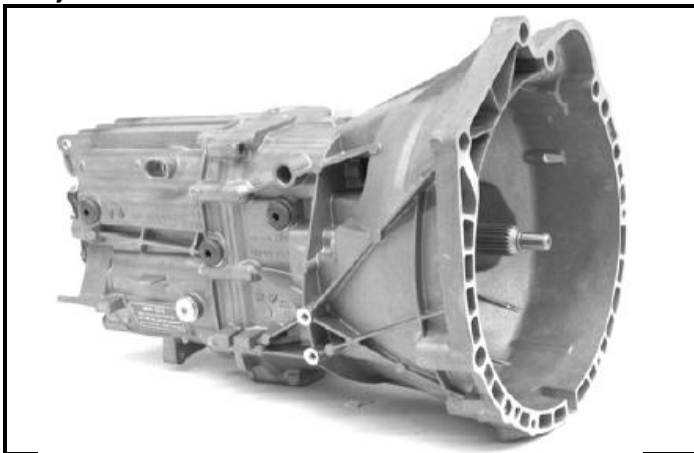

Cupla final( ver reglamento tecnico)

Carcasa de caja de velocidades de atrás

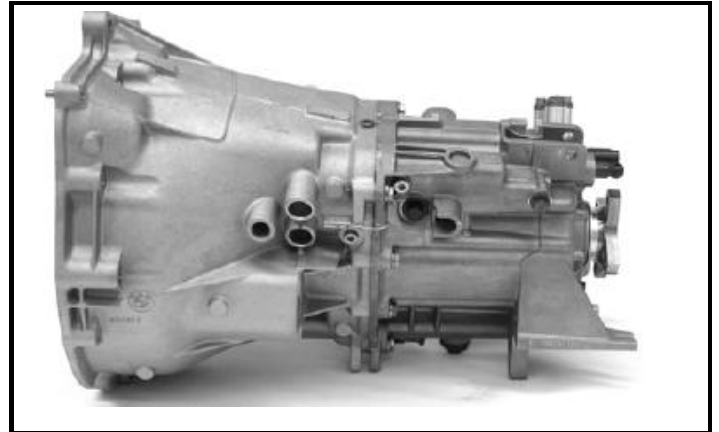

Caja velocidades : visto costado izquierdo

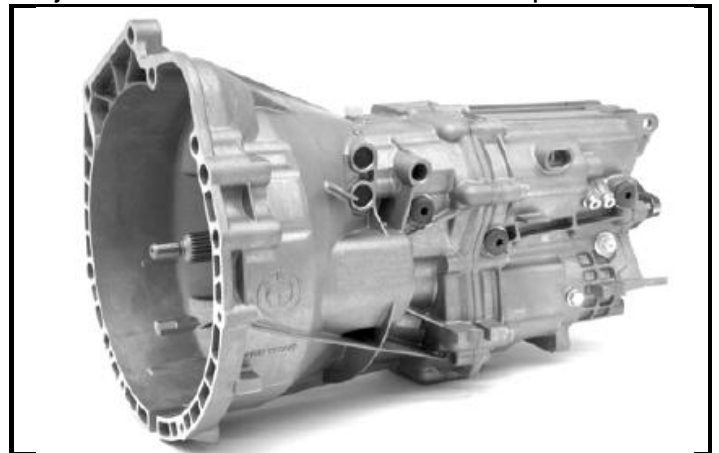

Tipo de cupla final

Engranajes helicoidal

Semi-ejes :

Originales provistos en auto de la marca

**SUSPENSION**

Delantera

Trasera

Tipo de suspension

Doble parrillas

Multilink

Resortes hélicoïdales

Si

Si

Suspensión delantera completa desmontada

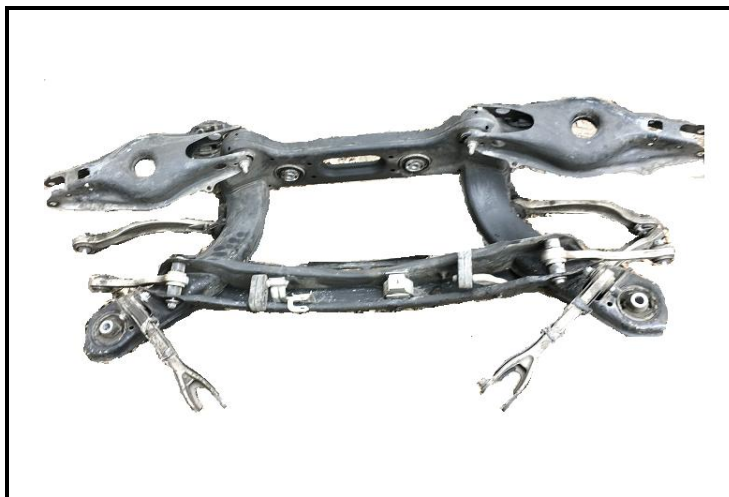

Sub chasis delantero visto de arriba

Suspensión trasera completa desmontada



Sub chasis delantero visto de abajo

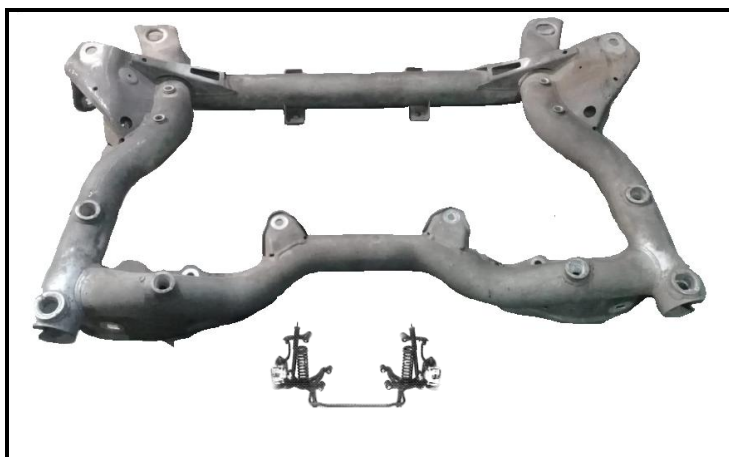

Sub chasis trasero visto de arriba



Sub chasis trasero visto de abajo

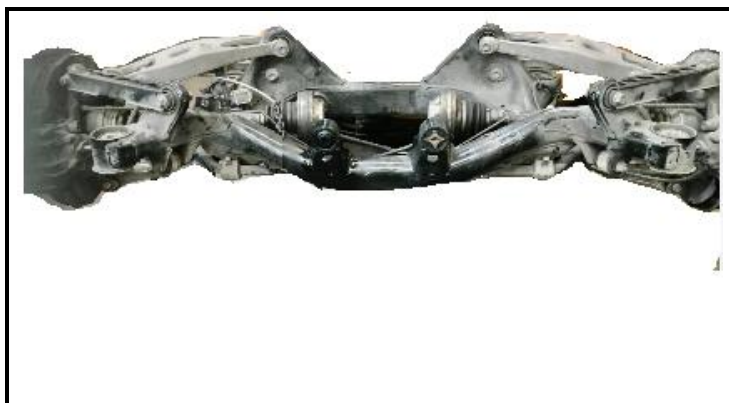

Frenos : Sistema de frenos Ver reglamento tecnico

Caja Direccion :  
Direccion hidraulica Si

Tipo Piñon y cremallera

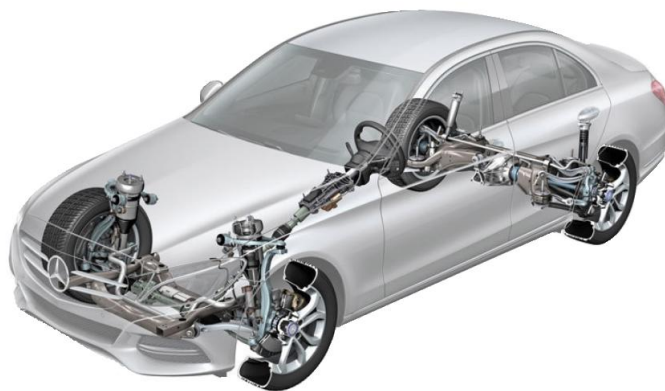

# Modificaciones permitidas por reglamento tecnico Clase Super



Ficha técnica N°  
**315**

Peso minimo biela original,cojinetes, tornillos,piston( recambio) ,perno y aros: 1000 g



Tapon en tapa cilindro derecha

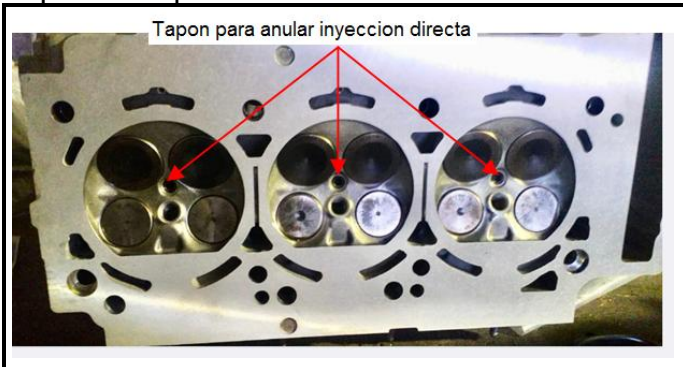

Tapon en tapa cilindro izquierda

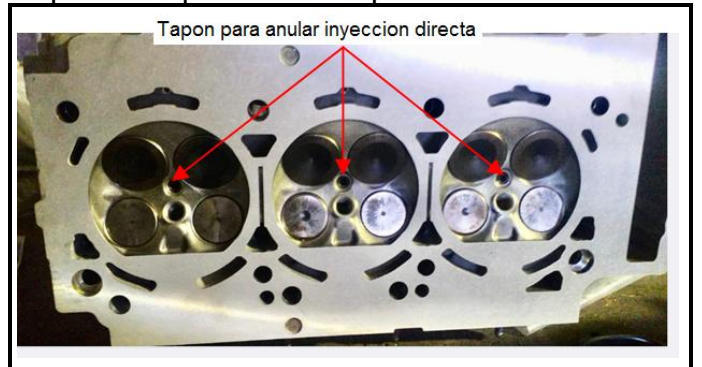

Multiple admision de arriba



Multiple admision de abajo

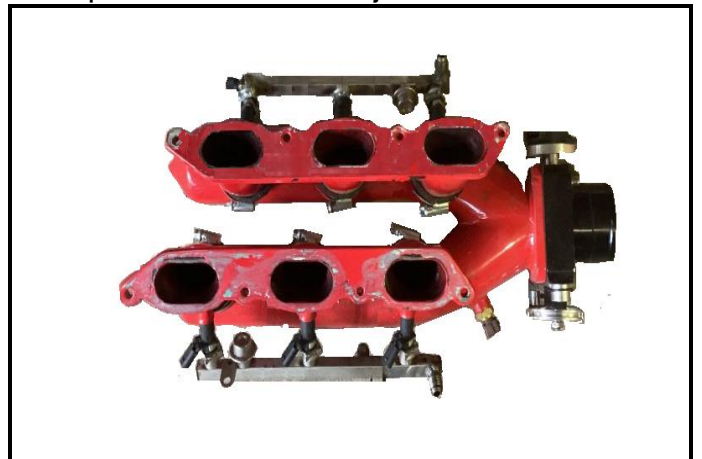

Volante peso minimo con tornillos fijacion 8500 kg

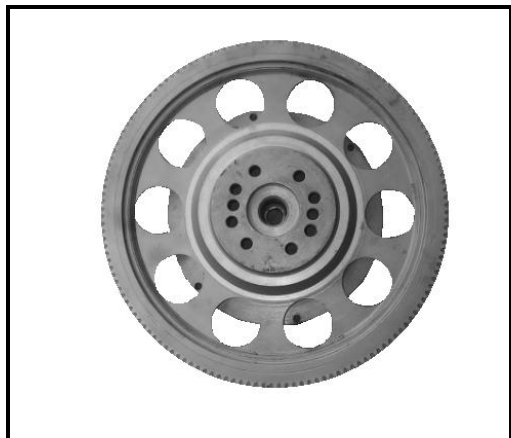

Volante de frente

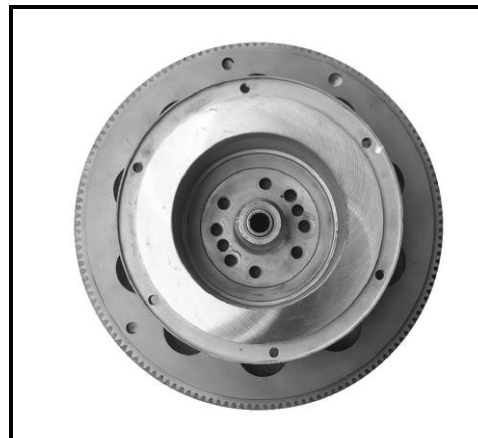

Brazo suspension delantero largo



Brazo suspension delantero corto



Brazo suspension delantera



Caja direccion en su nueva posicion

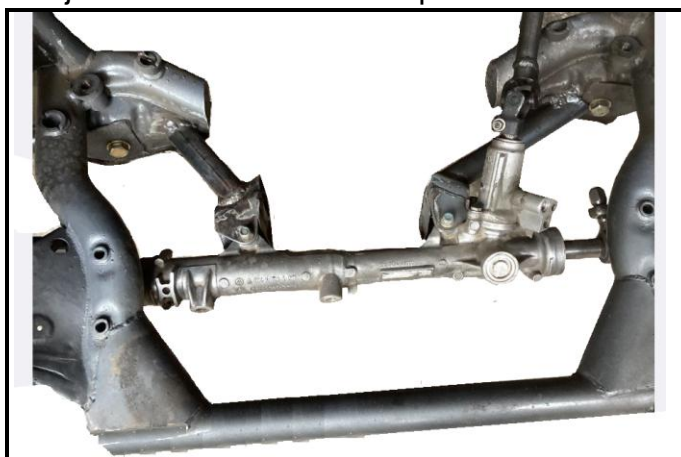

Adaptador motor caja : 17 mm +/-2mm

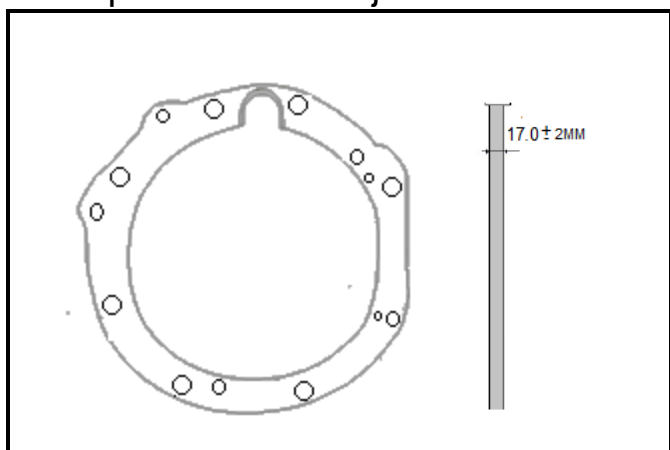

Adaptador motor caja





Cuerpo mariposa 73 mm



Rodillo medicion arbol levas 6.35mm

