

# **FICHA TÉCNICA BMW E46 COUPE**

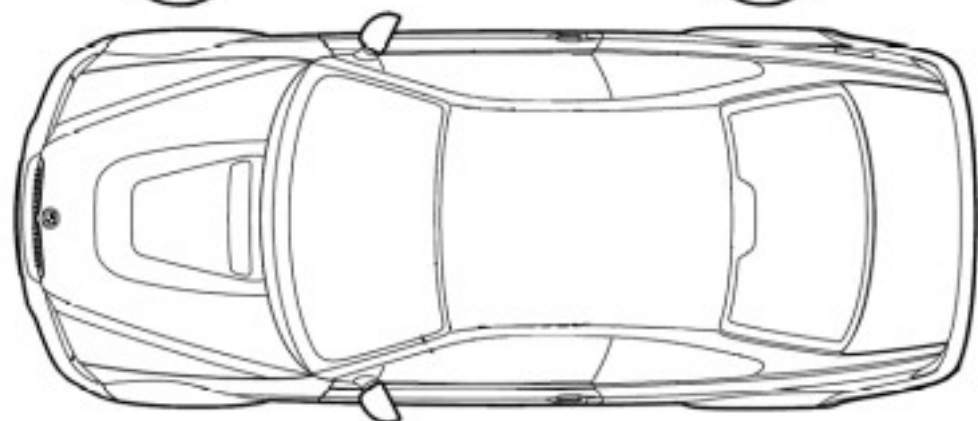
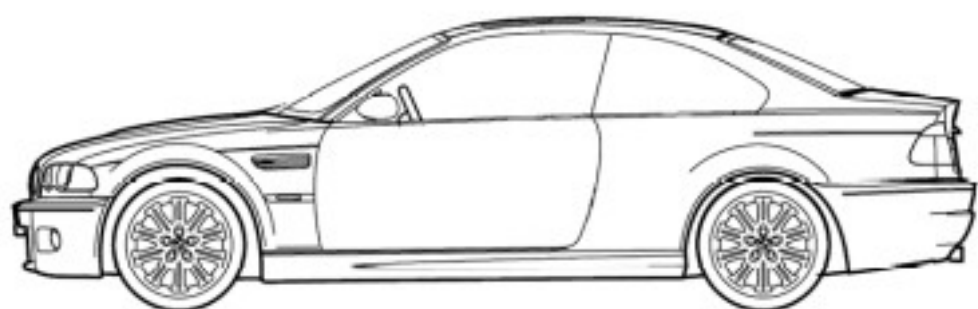

# Información BMW E46 Coupe

**VISTA 3/4 FRENTE**

**VISTA 3/4 TRASERA**

<b>Denominación(es) comercial(es)</b>	BMW E46 Coupe
<b>Números de volúmenes:</b>	3
<b>Números de plazas:</b>	5
<b>Longitud total:</b>	4488 mm +/- 1 %
<b>Distancia entre ejes Nominal:</b>	2725 mm +/- 1%
<b>Trocha delantera</b>	1790 mm
<b>Trocha trasera</b>	1790 mm
<b>Motor</b>	Ver Ficha Tecnica Motor asignado por usuario
<b>Peso</b>	1260Kg motor 3,0 / 1230kg motor 2.8
<b>Tanque de combustible – Cantidad: 1</b>	ubicación baul o bajo piso parte trasera
<b>Baterías - Cantidad: 1</b>	Tensión 12 volts

<b>Transmision</b>	Ruedas Motrices Traseras
<b>Embrague</b>	Original / Multidisco
<b>Caja de velocidades</b>	Marca Z F / Marca Ge TRAG
<b>Emplazamiento del comando</b>	Piso del habitáculo

	N.Diente s	Radios	Sincr
1	41 / 14	4.198	si
2	40 / 23	2.493	si
3	36 / 31	1.665	si
4	32 / 37	1.24	si
5		1.0	si

	N.Dientes	Radios	Sincr.
1	45 / 14	4.323	si
2	42 / 23	2.456	si
3	37 / 30	1.650	si
4	32 / 35	1.230	si
5		1.000	si

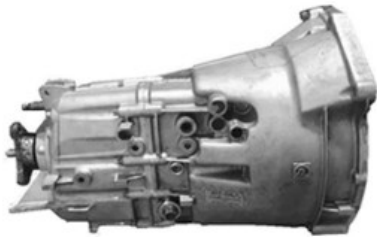

Caja de velocidades Vista costado derecho



Caja de velocidades Vista costado izquierdo



Caja de velocidades Vista costado derecho



Caja de velocidades Vista costado izquierdo

### INFORMACIÓN COMPLEMENTARIA

RELACIONES DE CAJA AUTORIZADAS EN GRADOS CON **5** VUELTAS DE MOTOR

CATEGORIA	<b>TURISMO INTERNACIONAL CLASE SUPER</b>						
MODELO AUTO	BMW : E36 - E46 – E90 – E90/93 – M3 – F30.			MERCEDES: C 200 – C280			
MOTOR: MARCA/MOD.	BMW : 328 (M52B28) – 330 (M54B30) – (N52B30)						
FICHA HOMOLOGACION	300 - 301- 302 -303 – 304 - 305 – 306 – 311.			315 – 321.			
CAJA	<b>“ Z F ”</b>						
REL.DIF	(13/42)=	(13/43)=	(13/44)=	( )=	(11/41)=	(12/47)=	( )=

**RELACIONES DE CAJA AUTORIZADAS EN GRADOS CON 5 VUELTAS DE MOTOR**

CATEGORIA		<b>TURISMO INTERNACIONAL CLASE SUPER</b>						
MODELO AUTO	BMW : E36 - E46 – E90 – E90/93 – M3 – F30.		MERCEDES: C 200 – C280					
MOTOR: MARCA/MOD.	BMW : 328 (M52B28) – 330 (M54B30) – (N52B30)							
FICHA HOMOLOGACION	300 – 301 – 302 – 303 – 304 – 305 -306 – 311.				315 - 321			
CAJA	<b>“G TRAG”</b>							
REL.DIF		(13/42)= 3,23	(13/43)= 3,30	(13/44)= 3,38	( )= 3,64	(11/41)= 3,73	(12/47)= 3,91	( )= 4,10
REL. CONST.	(39/29)= 1,344							
<b>1°</b>	<b>(45/14)= 4,319</b>	<b>129,18°</b>	<b>126,29°</b>	<b>123,30°</b>	<b>114,49°</b>	<b>111,73°</b>	<b>106,59°</b>	<b>101,65°</b>
<b>2°</b>	<b>(42/23)= 2,454</b>	<b>227,10°</b>	<b>222,27°</b>	<b>217,07°</b>	<b>201,52°</b>	<b>196,65°</b>	<b>187,59°</b>	<b>178,90°</b>
<b>3°</b>	<b>(37/30)= 1,657</b>	<b>336,32°</b>	<b>329,18°</b>	<b>321,42°</b>	<b>298,45°</b>	<b>291,26°</b>	<b>277,86°</b>	<b>264,97°</b>
<b>4°</b>	<b>(32/35)= 1,228</b>	<b>1V+ 93,85°</b>	<b>1V+ 84,22°</b>	<b>1V+73,73°</b>	<b>1V+ 42,77°</b>	<b>1V+ 33,01°</b>	<b>1V+14,92°</b>	<b>357,56°</b>
<b>5°</b>	<b>( )= 1</b>	<b>1V+197,27°</b>	<b>1V+ 185,45°</b>	<b>1V+172,54°</b>	<b>1V+ 134,50°</b>	<b>1V+ 122,57°</b>	<b>1V+100,35°</b>	<b>1V+ 79,02°</b>
<b>6°</b>	<b>(29/46)= 0,846</b>	<b>1V+298,85°</b>	<b>1V+ 284,93°</b>	<b>1V+269,59°</b>	<b>1V+ 224,60°</b>	<b>1V+ 210,52°</b>	<b>1V+184,29°</b>	<b>1V+ 159,03°</b>

**OBS:**



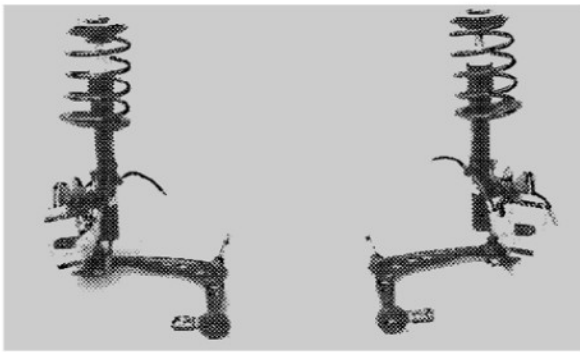

Suspensión delantera completa desmontada

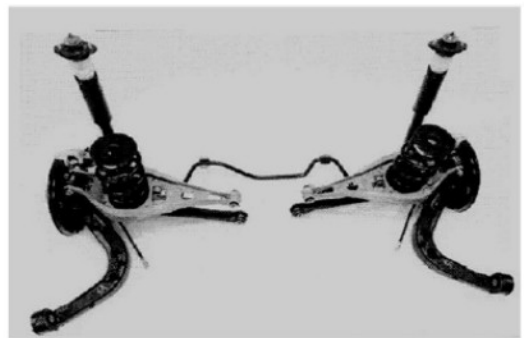

Suspensión trasera completa desmontada

SUSPENSION		
<b>Generalidades</b>	<b>Delantera</b>	<b>Trasera</b>
<b>Tipo de suspensión</b>	<b>Mac Pherson</b>	<b>Multilink</b>
<b>Resortes helicoidales</b>	<b>si</b>	<b>si</b>
<b>Amortiguadores</b>	<b>Delantero</b>	<b>Trasero</b>
<b>Cantidad por ruedas</b>	<b>1</b>	<b>1</b>
<b>Tipo</b>	<b>Telescópico</b>	<b>Telescópico</b>
<b>Principio de funcionamiento</b>	<b>Hidráulico</b>	<b>Hidráulico</b>

# **MODIFICACIONES PERMITIDAS POR REGLAMENTO TÉCNICO**

## **CLASE SUPER**



**Parrilla suspensión delantera**

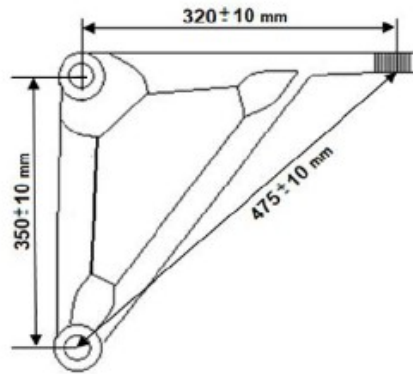

**Dibujo parrilla suspensión delantera**



**Brazo suspensión trasera de amortiguador**



**Parrilla suspensión trasera**



**Paragolpe delantero**

